

PART ONE: 2009 GCBSR ENTRY FORM

Schooner name: _____ Former name/s: _____
Sparred length: _____ Home port: _____ Arriving in Baltimore from: _____
Contact person: _____ Mobile phone: _____
Day phone: _____ Evening phone: _____ Fax: _____
Email: _____ Web site: _____
Captain (if different): _____ Owner (if different): _____
Permanent address: _____
Seasonal address & dates: _____
Shore side emergency contact during race week: _____
Day phone: _____ Evening phone: _____ Mobile phone: _____

CREW

Please list tentative crew. You will be asked to submit a final crew list at the Skippers' Meeting on Thursday morning.

crew & officers under 21: _____ # crew & officers 21 or over: _____ Total crew & officers: _____
paying passengers under 21: _____ # paying passengers 21 or over: _____ Total paying passengers: _____
Total persons under 21: _____ Total persons 21 or over: _____ Total persons on board: _____

HOSPITALITY

Docking preference: Starboard side to Port side to No preference *If available:* Electric volts/amps: _____
Open to the public? No Yes, Baltimore on Wednesday Yes, Portsmouth on Saturday Yes, Portsmouth on Sunday
Room for volunteers or sponsors for the Parade of Sail? No Yes If Yes, how many? _____
Any dietary restrictions? No Yes If Yes, please describe: _____

FLOAT PLAN

Day & date of estimated arrival in Baltimore: _____ AM PM
Day & date of estimated departure from Portsmouth: _____ AM PM
If you do not expect to attend race events in both ports, please advise: _____

SAFETY EQUIPMENT

EPIRB VHF GPS SatNav Radar WeatherFax SSB Life raft Dinghy/yawl boat Trysail Storm jib
Other: _____

BOAT DATA

Draft: _____ Beam: _____ Freeboard: _____ Hull material: _____
Designer: _____ Design, type or model name: _____
Builder/rebuilder: _____ Build/rebuild location: _____
Built/rebuilt year: _____ Power: _____ Working sail area (lowers): _____
Photo: None Attached Sent to race@schoonerrace.org Bio/press kit: None Attached Sent to race@schoonerrace.org

HOLD HARMLESS

Please read before signing. I agree to abide by the regulations & sailing instructions for this event, &, by signing below, confirm that I have read the attached Safety Statement & that my vessel conforms in all respects. I hereby agree that neither I nor any of my crew members, cadets or passengers shall hold the Great Chesapeake Bay Schooner Race, Inc., nor any of its personnel responsible for damage, accidents or injuries during the race or related activities; no person shall be aboard my vessel who has not consented to this waiver in his or her behalf. I understand that organizers may transfer to third parties the right to film or tape part or all of the event for eventual license, sale or distribution, & agree that neither organizers nor such third party has any obligation to compensate entrants in any form.

Signed: _____ Title: _____ Date: _____

Check here if you decline permission for us to trade your address with related non-profits (ASTA, ASA, CBF, Mystic). We very seldom share our mailing list.

PART TWO: 2009 GCBRSR HANDICAPPING DATA FORM

Schooners will be rated under the 1974 Off Soundings Club Rating Rule. Its basis is the amount of theoretical sail area (lowers) you have room for, not your actual inventory. Owners are reminded that boats as built always differ from their line drawings — we recommend you measure the boat, not her plans. **Even if your handicapping data is on file with us, please complete ALL of this form.**

Schooner name: _____

Completed by: _____ **Date:** _____

Mainsail rig: Marconi Gaff None Unstayed

Number of masts: _____ **Number of propellers:** _____

Prop type: Solid Feather/Fold

blades: _____

Prop size: _____ x

No engine? Describe towed yawl boat (LWL, prop, draft, etc.):

SPECIAL DOCKING NEEDS? Please explain: _____

Note: We may make allowances for excess displacement, oversized props, etc., so if you feel your schooner has not been properly rated or classed, please let the Race Committee know of your concerns. The Race Committee reserves the right to adjust ratings to promote competitive racing.

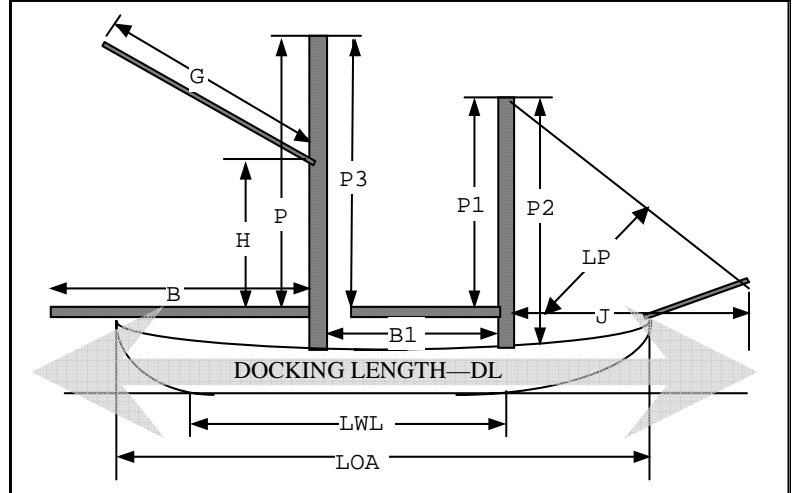

Please state measurements in feet & inches to the nearest whole inch.

FT IN

		FT	IN
LOD: Length on deck. (This may be on your documentation as "LOA.")	LOD		
LWL: Waterline length.	LWL		
Beam: Maximum beam.	Beam		
DL: Docking length. (We need to know how much space you will take up!)	DL		
B: Distance from fair extension of aft side of mainmast, sail track or groove to aftermost position to which mainsail clew can be extended, or inner edge of boom black band.	B		
B1: Distance at deck between forward side of mainmast & after side of next mast.	B1		
B2: (3 & 4-masters only) see B1 above for third mast.	B2		
B3: (4-masters only) see B1 above for fourth mast.	B3		
J: Distance from forward side of mast at deck to intersection of foremast stay on which foremost headsail is normally carried, with top of bowsprit, if used, or top of rail including cap.	J		
P: Distance from fair extension of top of boom track when touching lowest point of gooseneck, or from top of black band, if used, to top of main halyard sheave or to underside of masthead black band, if used & appropriate halyard marking is included.	P		
P2: Distance from intersection of forward face of mast with centerline of main deck to intersection of forward face of mast with centerline of headstay or strop carrying highest headsail.	P2		
P1: Perpendicular measured along after side of mast from top of highest halyard block used for sails aft of mast to upper side of boom when at lowest position of gooseneck.	P1		
P4: (3 & 4-masters only) see P1 above for third mast.	P4		
P6: (4-masters only) see P1 above for fourth mast.	P6		
P3: Perpendicular measured along forward side of mast, from top of highest halyard block used for sails forward of mast, to upper side of boom when resting parallel to deck against the lowest point of gooseneck. If no fisherman staysail carried, measure from point opposite highest halyard block on after side of mast.	P3		
P5: (3 & 4-masters only) see P3 above for third mast.	P5		
P7: (4-masters only) see P3 above for fourth mast.	P7		
G: Extreme length of gaff, when lying on top of boom, to the mast proper.	G		
H: Perpendicular measurement along after side of mast, from throat cringle of sail to upper side of boom.	H		
LP: Shortest distance between extreme after end of clew cringle & forward side of luff rope.	LP		

PART THREE: 2009 GCBSR SHIRT ORDER FORM

Schooner name: _____

Contact person: _____ Phone: _____

This year you will receive top-quality, heavy-weight, 100% cotton, long-sleeved, crew-necked tees, delivered to you in Baltimore. Prices include tax. Only sizes listed are available. They make great souvenirs or gifts. Additional race merchandise, including short-sleeved shirts, sweatshirts, hats, etc., will be available in Baltimore and Portsmouth.

Official race shirts serve as your admission ticket to all events, so order at least as many shirts as you have persons on board. *The first two shirts are free.* For orders of 12 or more shirts, we will print your schooner's name on them (no additional charge).

Quantity of Each Size	Qty	@ Price	= Total
Small:			
Medium:	2 for Captain & Mate:	Free	
Large:	# for on-board crew:		
Extra large:	# additional shirts:		
XX large:	Quantity ordered*: <input style="width: 50px;" type="text"/>		
TOTAL quantity ordered*:	<input style="width: 50px;" type="text"/>	TOTAL shirt fees:	<input style="width: 50px;" type="text"/>

* "Quantity ordered" should be the same in both boxes.

PART FOUR: 2009 GCBSR PAYMENT

Tax-deductible entry fee of **per foot of LOA** _____

Surcharge for paying passengers: #_____ @ _____ per passenger..... _____

Total shirt fees _____

Optional tax-deductible donation** to support the race _____

Total amount remitted..... _____

If forms will be mailed & you prefer to pay by check, money order or traveler's check, these should be made payable to GCBSR.
 If forms will be faxed or sent via email, please complete MasterCard or Visa information below or make payment with a credit card via PayPal at www.schoonerrace.org.

Visa MasterCard Card # _____

Exp. _____ Print name on card: _____

 Billing address for card: _____

** Donations will be listed under your schooner's name on promotional materials unless you specify otherwise: